

THE INNOVATIVE

TRACK BALLAST SHOULDER

RETENTION SYSTEM

DESIGNED FOR THE RAIL INDUSTRY



Authorised for use by  
London Underground

Reg No: 3082



PA05/06325



asset BaFix™ Manual V9

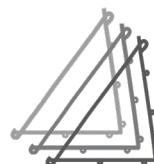

asset|BaFix™  
BALLAST RETENTION SYSTEM



## CONTENT



- 02. Approval and Benefits
- 03. Securing the Ballast
- 04. Product Weight, Delivery and Design
- 05. **asset BaFix™ 50 Detail**
- 06. **asset BaFix™ 70 Detail**
- 07. **asset BaFix™ 100 Detail**
- 08. Typical Layouts of **asset BaFix™ 50, 70 and 100**
- 09 - 10. Installation Guide for the **asset BaFix™ System**
- 11. Description of Bill of Materials per 6m Length - Height 0.50m
- 12. Description of Bill of Materials per 6m Length - Height 0.70m
- 13. Description of Bill of Materials per 6m Length - Height 1.00m
- 14 - 15. **asset BaFix™ used within OLE Works**
- 16. **asset BaFix™ featuring Sleeve-It**
- 17. **asset BaFix™ featuring Sleeve-It and Fence Systems**
- 18 - 20. **asset BaFix™-Geo**

## Approval and Benefits



**asset BaFix™** is used and approved by Network Rail (PA05/06325), authorised for use by 'LU' (Reg No. 3082) and is used by Irish Rail. **asset BaFix™** provides an innovative track ballast shoulder retention system designed for the rail sector. The benefit of installing the **asset BaFix™** system is in preventing the loss of ballast over time, creating a long term stable border for the ballast.

Ballast retention saves money, eliminates damage to cable troughs or ducts, maintains acceptable levels of safety and line speed.

In addition, **asset BaFix™** offers future improvements such as raising the track level if required. It can also be used in the National Electrification programme OLE in conjunction with retaining ballast around cantilever masts.

*asset BaFix™ has a design life of up to 120 years taking into account whole life costs. Some of the key benefits of the systems may include: savings in reducing loss of ballast, labour costs savings and in supporting the ballast shoulder whilst maintaining track speed used on a national basis.*

## The advantages of the asset BaFix™ Ballast Retention System

FULLY USED AND APPROVED BY NETWORK RAIL AND LU

USED BY IRISH RAIL

LIGHT WEIGHT MATERIAL 6M LONG asset BaFix™ 50 (39kg), asset BaFix™ 70 (45.8kg) and asset BaFix™ 100 (61.1kg)

REDUCED WHOLE LIFE COSTS

CREATES A STABLE LEVEL ADJACENT TO THE TRACK

QUICK AND EASY REDUCING INSTALLATION TIME WHILST BACKFILLING COMPARED TO BALLAST BOARDS

CAN BE FILLED USING AUTOMATIC CONVEYOR SYSTEMS

ALLOW CABLE TROUGHS OR DUCTS TO BE INSTALLED AND MAINTAINED WITHIN THE SYSTEM

PALISADE FENCING POST OR KEY CLAMP SYSTEM ANCHORED WITHIN THE SUPPORTED BaFix STRUCTURES

## Securing the Ballast

Installing **asset BaFix™** provides a robust solution to long-term railway maintenance issues. The product is available in three heights including 500mm, 700mm or 1000mm. The front panel is made of high quality aluminium - zinc alloy coated mesh formed with an inclination of 80°.

### asset BaFix™ Rail Track Ballast Shoulder Details

Please note that all dimensions are quoted in mm

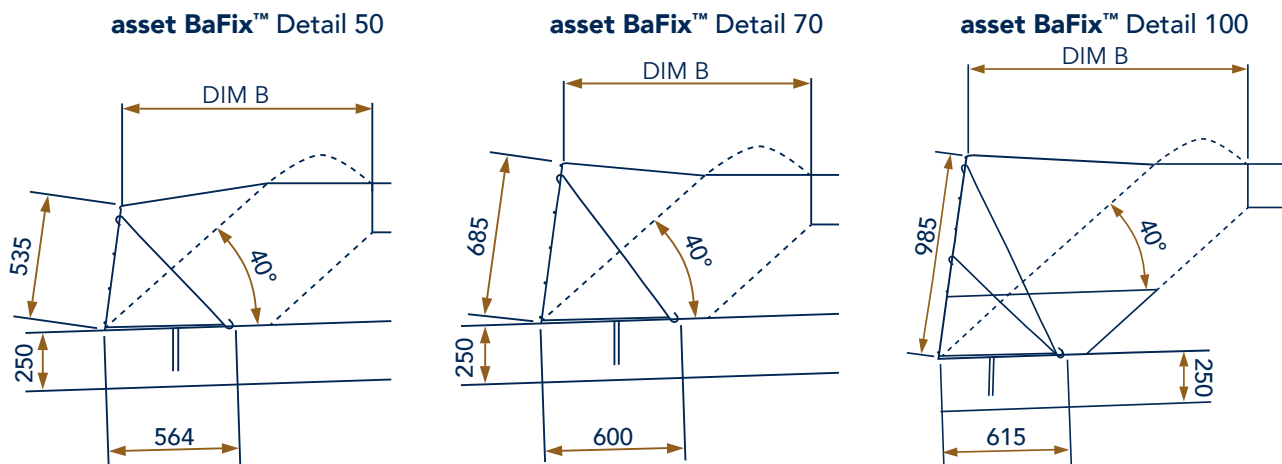

**asset BaFix™** has been placed outside the load transfer zone from underside of sleeper taking into account the stakeholders comments.

The front face of the **asset BaFix™** mesh retains fill outside the minimum shoulder width and does not compromise the track design.

The system creates a stable level permanent way for operatives to work within. In the event of an evacuation of a train the level cess walkway could form a continuous position of safety.

### Why use asset BaFix™?

The **asset BaFix™** system will reduce the levels of maintenance caused by the loss of the ballast shoulder overtime. It may assist in the following situations by reducing:

- **Lateral stability caused by ballast tamping**
- **Loss of ballast during flooding or on soft ground issues**
- **Loss of ballast at the intersection of the rail overbridge with a road underbridge**

The installation of the **asset BaFix™** ballast retention system must adhere to the minimum dimensions contained within the tables on pages 5, 6 and 7.

**For further information please contact [info@assetint.co.uk](mailto:info@assetint.co.uk)**

The benefits of using a light weight containment unit in 6m lengths is that it is more economical and it maintains a long design life. It's fast installation method is a benefit against most conventional rail retaining methods.

## Product Weight, Delivery and Design

**asset BaFix™ units are 6.0m long**

### Typical Weights

asset BaFix™ 100 (0.97m high x 0.62m wide x 6.0m long) = 61.1kg

asset BaFix™ 70 (0.68m high x 0.60m wide x 6.0m long) = 45.8kg

asset BaFix™ 50 (0.53m x 0.56m wide 6.0m long) = 39.0kg

## Geometric Parameters using the asset BaFix™ System

- 20 pieces per bundle, maximum bundle
  - asset BaFix™ 100** weight 1222kgs
  - asset BaFix™ 70** weight 916kgs
  - asset BaFix™ 50** weight 780kgs
- A full articulated vehicle would accommodate 220 pieces.  
A half articulated vehicle load would accommodate 100 pieces.
- For installation we recommend two operatives to lift the **asset BaFix™ 50** and **70**, and three operatives for the 100 to install a 6m long element without excavation and backfilling in approximately 15 minutes (for costing calculating using 0.5 man hours per 6m piece).  
Please refer to the **SAFE MANUAL HANDLING OPERATIONS** – STFC Safety Code No12 for installation guidance.
- Opening width of front mesh: 30 x 142mm.
- Wire diameter: Span bars 5.0mm, cross bars 8.0  
Coating class A to EN-10244-2.
- Backfill material we recommend ballast material (crushed stone 32/50mm).
- Compaction equipment we recommend within this distance of 500mm area small vibratory plate (50-100kg). Outside of the 500mm area the use of standard rail approved equipment is required.
- The geometrical parameters below to be observed when using the **asset BaFix™** system.  
A maximum superimposed Live Load of 5.0 KN/m<sup>2</sup> for maintenance this includes SLS Y FL = 1-1.
- With a design life in excess of **120 years**, the **asset BaFix™** system is manufactured and supplied in accordance with the requirements of **BS EN 10223-8:2013** where the mesh panels and ancillary items are considered to have a life expectancy of **120 years** in a 'Corrosion category C3' (based on ref. **BS EN ISO 9223:2012** Table 1, Design life **BS EN 10223-8:2013**, Corrosion allowance **BS EN ISO 9224**).

## Track Renewals Ballast Shoulder Retention System

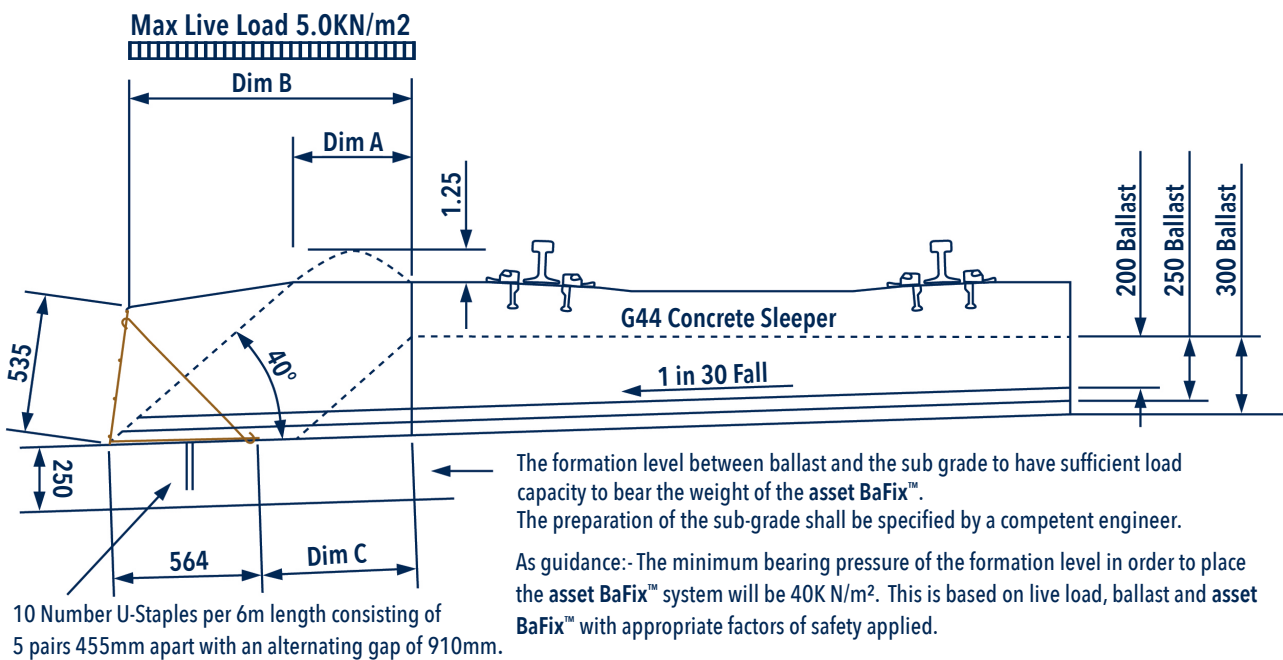

Note:- Staples could be removed and replaced with a 1.2m wide geogrid fixed to the asset BaFix™ to prevent lateral movement during installation.

			Minimum dimension for asset BaFix™	
Depth of Ballast mm	Height of Shoulder above sleeper top mm	Minimum Shoulder width Dim A mm	Top (Dim B) mm	Bottom (Dim C) mm
200	125 in all cases	375	890	405
		450	970	485
250	125 in all cases	375	950	465
		450	1030	545
300	125 in all cases	375	1000	515
		450	1070	585

## Track Renewals Ballast Shoulder Retention System

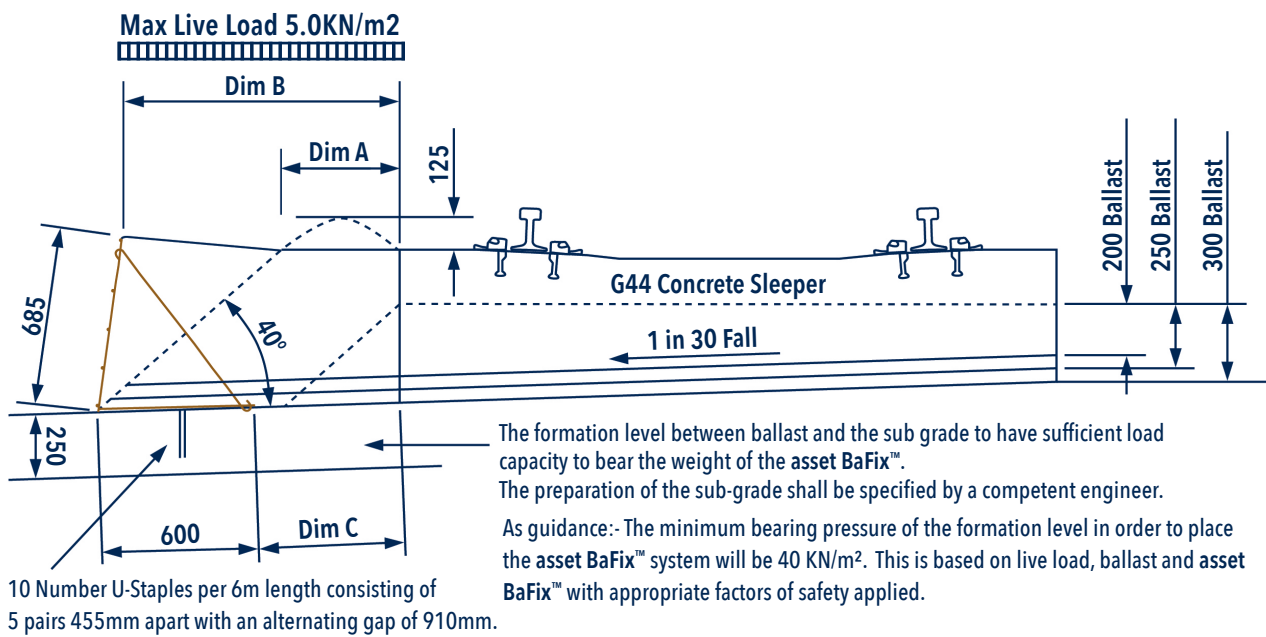

Note:- Staples could be removed and replaced with a 1.2m wide geogrid fixed to the asset BaFix™ to prevent lateral movement during installation.

			Minimum dimension for asset BaFix™	
Depth of Ballast mm	Height of Shoulder above sleeper top mm	Minimum Shoulder width Dim A mm	Top (Dim B) mm	Bottom (Dim C) mm
200	125 in all cases	375	870	370
		450	945	445
250	125 in all cases	375	925	430
		450	1005	505
300	125 in all cases	375	970	470
		450	1045	550



asset BaFix™ 100 detail

asset BaFix™ 100 detail

Track Renewals Ballast Shoulder Retention System

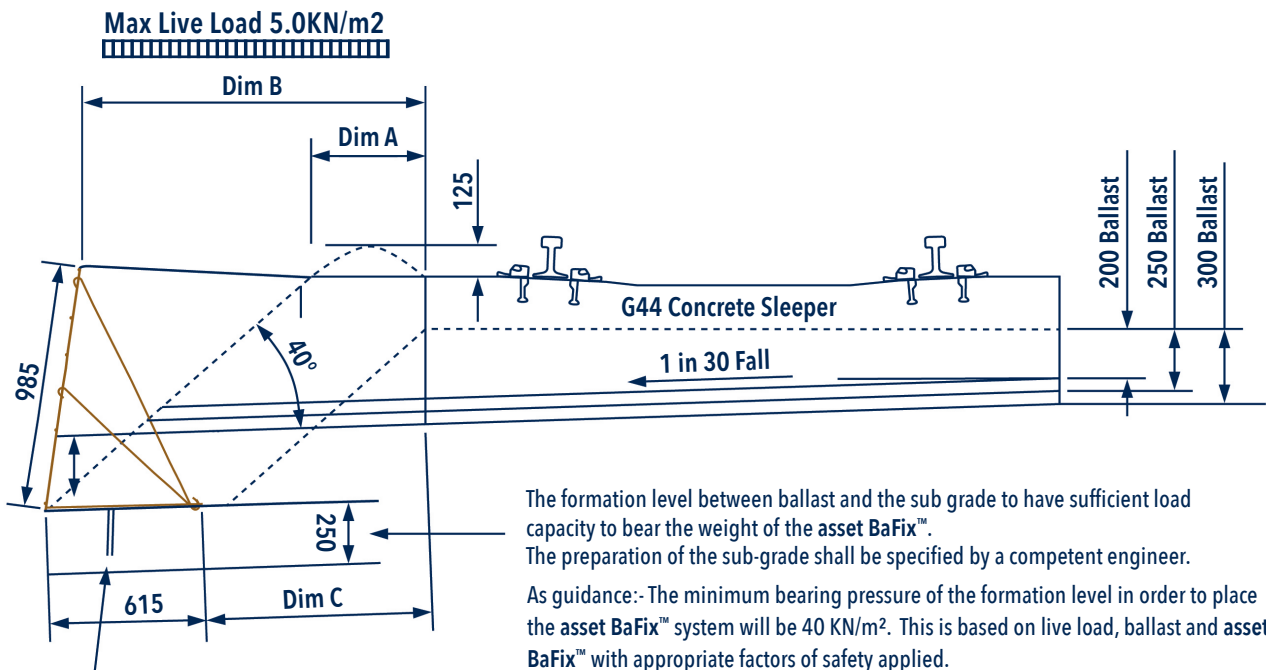

10 Number U-Staples per 6m length consisting of 5 pairs 455mm apart with an alternating gap of 910mm.

Note:- Staples could be removed and replaced with a 1.2m wide geogrid fixed to the asset BaFix™ to prevent lateral movement during installation.

			Minimum dimension for asset BaFix™	
Depth of Ballast mm	Height of Shoulder above sleeper top mm	Minimum Shoulder width Dim A mm	Top (Dim B) mm	Bottom (Dim C) mm
Varies	125 in all cases	375	1270	810
		450	1350	890

asset BaFix™ 50

asset BaFix™ 70

asset BaFix™ 100

Typical Layouts of asset BaFix™ 50, 70 and 100

Re: asset BaFix™ 50 Grid

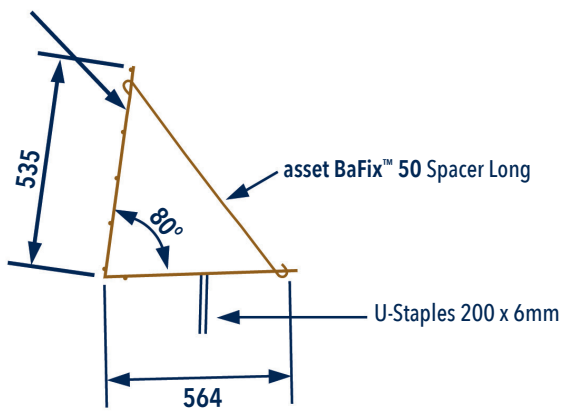

asset BaFix™ 50 Detail

Re: asset BaFix™ 100 Grid

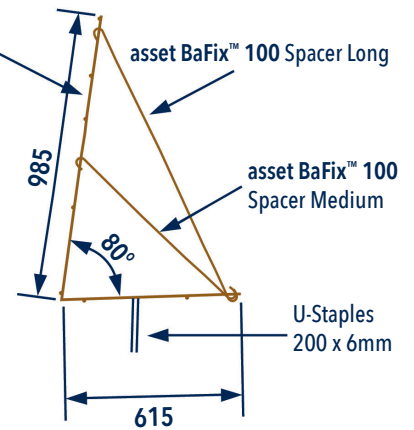

asset BaFix™ 100 Detail

Re: asset BaFix™ 70 Grid

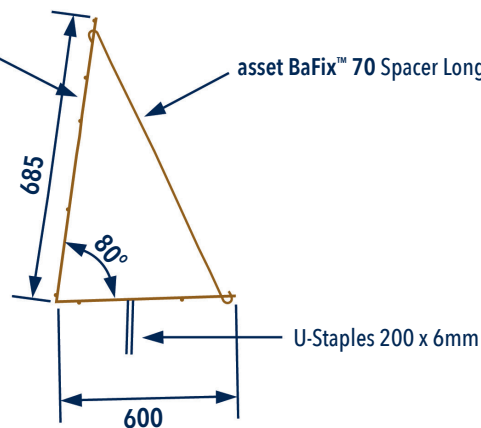

asset BaFix™ 70 Detail

# Installation Guide for the asset BaFix™ System

## Foundation/Base Grade - Offsetting/Mounting - Building along the length

### 1. Foundation/ base grade

The subsurface must have sufficient load capacity to bear the weight of the asset BaFix™. In line with system requirements, a gravel sand layer of min.25cm is recommended. The subsurface or gravel sand layer must be well compacted along the entire installation width. Additional ground-stabilising measures are required if the ground has a low load capacity or is water-sensitive. To enable the front elements to be positioned correctly, a 1.0m-wide horizontal plane (+/-1cm) must be created at the base of the slope face. [Fig. 1]

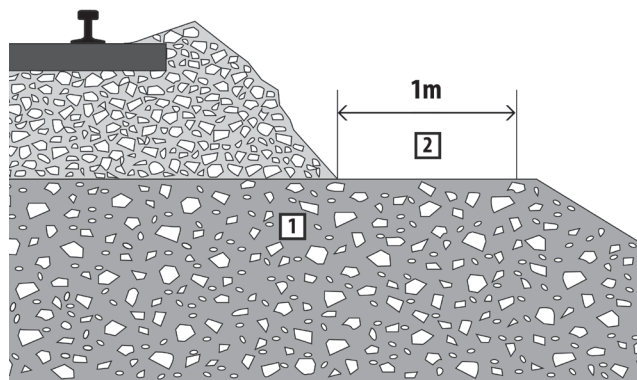

[Fig. 1]

The assessment of the subsurface load capacity must always be verified by a local engineer and must be checked by the project management or approving authority.

As guidance:- The minimum bearing pressure of the formation level in order to place the asset BaFix™ system will be 40KN/m<sup>2</sup>. This is based on live load, ballast and asset BaFix™ with appropriate factors of safety applied.

### 2. Offsetting/mounting

- A Place the front element on the prepared grade.  
The elements must be offset backwards from the slope face at a distance that is required for the load capacity.
- B Position the spacers at a distance of 45cm.  
The correct place for hooking is always between the two bars located next to each other at the base and the second bar from the top. They must be hooked in an upright position as per figure 2. [Fig. 2]
- C Position the front element correctly and secure it to the grade using the U-staple(10NO.per 6m length).

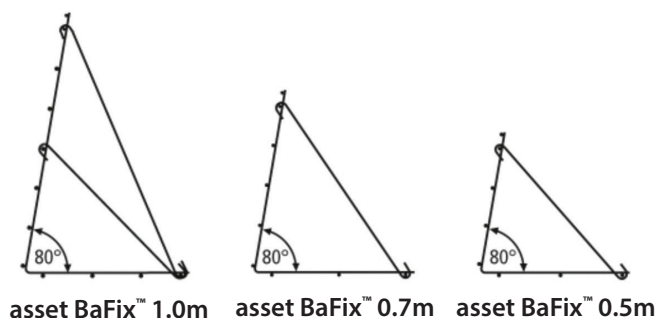

[Fig. 2]

## Installation Guide for the asset BaFix™ System

### Foundation/Base Grade - Offsetting/Mounting - Building along the length

#### 3. Building along the length using additional asset BaFix™ installation package

The front elements are connected to the ground element using the supplied connecting rods (first and last horizontal wire) and by means of contact clamps at the front connected [Fig.3]

1. Front Mesh
2. Spacer Long
3. Connecting Pipe
4. Terminal contact used for earthing when used with OLE (overhead line equipment)

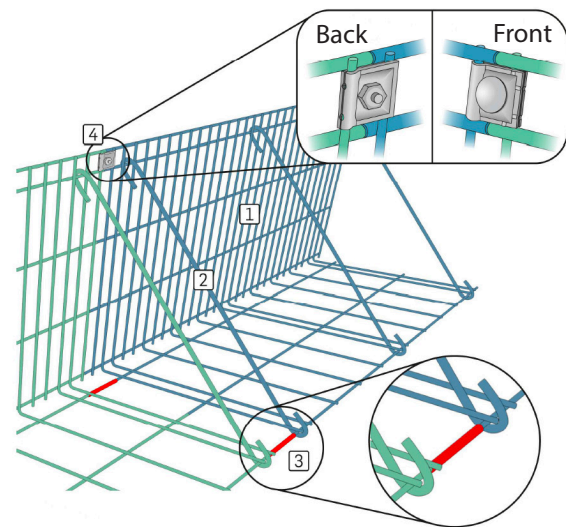

[Fig. 3]

#### 4. Backfill

The standards for the respective tracks must be observed for the ballast backfill material 32/50m. Compaction equipment within 500mm area small vibratory plate (50-100kgs) Outside of the 500mm area with the use of standard rail approval equipment is required.

The opening width of the front mesh measures 30 x 142mm.

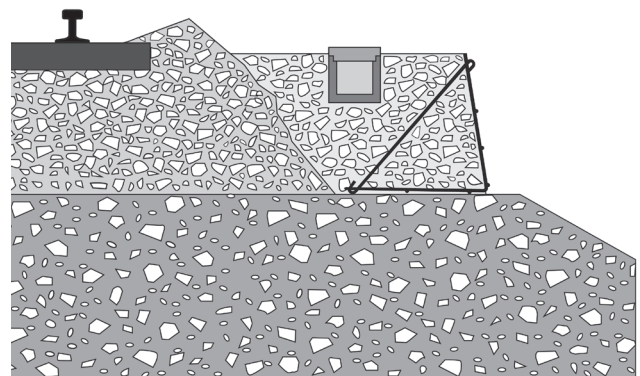

#### 5. Required installation accessories

Angle grinder for cutting the front elements (for potential modification).

## asset BaFix™ Materials

### Description of Bill of Materials per 6m Length - Height 0.50m

Vertical Construction height	0.50m
Length of Elements	6.00m
Gradient	80°
Opening Width of Front Grill	30 x 142mm
1 Packet = 3.00m <sup>2</sup> Vertical Surface Area	

Product Number	Description	Quantity	Unit	Network Rail Catalogue No.	Custom Tariff Number
MP2BF50GRID	Ref: <b>asset BaFix™ 50</b> Grid Front element <b>asset BaFix™</b> 0.5 x 6m@80° Al/Zn	1.00	pc	057/072437	7314.4100
MP2BF50SL	Ref: <b>asset BaFix™ 50</b> Spacer Long Spacer Long 80°, Al/Zn, length : 684mm	14.00	pc	057/072438	7326.2000
MP2BF80PIPE	Ref: Connecting Pipe 80mm Connecting Pipe 80mm/D=12 x 1,0mm	2.00	pc	057/072433	7306.4021
MP2BFSTAPLE	Ref: U - Staple U - Staple 200 x 6mm	10.00	pc	057/072434	7326.9098
MP2BFCONTACT	Ref: Rail Contact Clamp Rail Contact Clamp - 19 x 15 x 15 mm	1.00	pc		8538.9040

**HEIGHT 0.50M**



## asset BaFix™ Materials

### Description of Bill of Materials per 6m Length - Height 0.70m

Vertical Construction height	0.70m
Length of Elements	6.00m
Gradient	80°
Opening Width of Front Grill	30 x 142mm
1 Packet = 4.20m <sup>2</sup> Vertical Surface Area	

Product Number	Description	Quantity	Unit	Network Rail Catalogue No.	Custom Tariff Number
MP2BF70GRID	Ref: <b>asset BaFix™ 70</b> Grid Front element <b>asset BaFix™</b> 0.5 X 6m@80° A/Zn	1.00	pc	057/072435	7314.4100
MP2BF70SL	Ref: <b>asset BaFix™ 70</b> Grid Spacer Long 80°, Al/Zn, length : 803mm	14.00	pc	057/072436	7326.2000
MP2BF80PIPE	Ref: Connecting Pipe 80mm Connecting Pipe 80mm/D=12 x 1,0mm	2.00	pc	057/072433	7306.4021
MP2BFSTAPLE	Ref: U - Staple U - Staple 200 x 6mm	10.00	pc	057/072434	7326.9098
MP2BFCONTACT	Ref: Rail Contact Clamp Rail Contact Clamp - 19 x 15 x 15mm	1.00	pc		8538.9040

**HEIGHT 0.70M**



## asset BaFix™ Materials

### Description of Bill of Materials per 6m Length - Height 1.00m

Vertical Construction height	1.00m
Length of Elements	6.00m
Gradient	80°
Opening Width of Front Grill	30 x 142mm
1 Packet = 6.00m <sup>2</sup> Vertical Surface Area	

Product Number	Description	Quantity	Unit	Network Rail Catalogue No.	Custom Tariff Number
MP2BF100GRID	Ref: <b>asset BaFix™ 100</b> Grid Front element <b>asset BaFix™</b> 1.0 x 6m' 80° Al/Zn	1.00	pc	057/072430	7314.4100
MP2BF100SL	Ref: <b>asset BaFix™ 100</b> Grid Spacer Long 80°, Al/Zn, length : 1036mm	14.00	pc	057/072431	7326.2000
MP2BF100SM	Ref: <b>asset BaFix™ 100</b> Spacer Medium Spacer medium 80°, Al/ Zn, length: 811mm	14.00	pc	057/072432	7326.2000
MP2BF80PIPE	Ref: Connecting Pipe 80mm Connecting Pipe 80mm/D=12 x 1,0mm	2.00	pc	057/072433	7306.4021
MP2BFSTAPLE	Ref: U - Staple U - Staple 200 x 6mm	10.00	pc	057/072434	7326.9098
MP2BFCONTACT	Ref: Rail Contact Clamp Rail Contact Clamp - 19 x 15 x 15mm	1.00	pc		8538.9040

**HEIGHT 0.1M**

## asset BaFix™ used within OLE Works

### Standard asset BaFix™ Fabrication Details

#### OLE Mast Foundation

Overhead Line Equipment – or OLE the name railway engineers give to assembly of masts, gantries and wires found along electrified Railways. New systems of OLE are being adopted on Britain’s railways. **asset BaFix™** is designed to support the rail track ballast. Using our standard fabrication elements would offer a complete system designed to accommodate the OLE masts foundation.

The **asset BaFix™** system must be earthed by the railway contractor. Terminal contact development for the system connects the individual elements allowing the contractor to connect the **asset BaFix™** to the grounding system at any point.

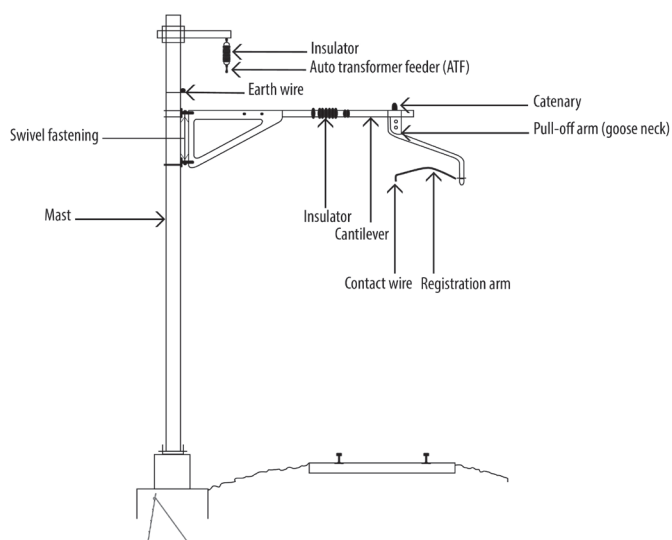



## asset BaFix™ used within OLE Works

### Standard asset BaFix™ Fabrication Details

#### Bridge Abutment Detail

Using a standard **asset BaFix™** fabrication detail would enable the system to be modified, taking into account a change of direction. The bespoke fabrication unit could be designed to finish flush to a reinforced concrete abutment.



#### Usage

- Bespoke fabrication units available
- Maintains ballast deformation
- Reduces temporary works
- Has a design life of up to 120 years
- Can be connected to a grounding system at any point



## asset BaFix™ Featuring Sleeve-It

The additional product can be used with asset BaFix™

### Tested Pre-Engineered Fence Post Anchoring System

When using the **asset BaFix™** there could be a requirement to protect important trackside equipment, secure from trespass and prevent operatives working on the railway where there is a risk of a fall from height. **Sleeve-It** is a pre-engineered fence post, anchoring system that can be used as an accessory to the rail approved **asset BaFix™**. **Sleeve-It** can be utilised as a solution for resisting various loading configurations as stated in **BS1722** Part 14 including personnel loading 740N/m at a height of 1.1m above ground level, dynamic pressure from wind loading 900N/m<sup>2</sup> if the site is not subject to extreme or abnormal loading. **Sleeve-It** is suitable for integrating either handrail, key clamp barriers or fencing systems such as a palisade fencing providing into a stable fence footing.

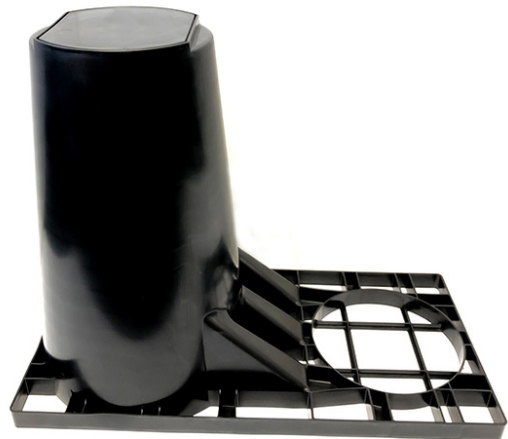

### asset BaFix™ featuring Sleeve-It

#### 3 step **Sleeve-It** installation in conjunction with asset BaFix™

1. Install the **Sleeve-It** unit creating at least a 50mm gap at the top of the unit to the front face of the **asset BaFix™**.
2. Backfill material to comply with the rail authorities ballast standards. Asset in dialogue with Network Rail recommend a ballast material (crushed stone 32/50mm).
3. Top cap to be knocked out, the unit shall be filled with either C8/10 or ST2 concrete conforming to BS 8500 -1 and BS 8500 – 2. The concrete shall be well rammed as the filling proceeds. Concrete around steel posts shall be finished with a weathered top to prevent accumulation of water.



## asset BaFix™ Featuring Sleeve-It and Fence Systems

### Example applications that could prevent long term maintenance issues

#### Example Applications

Designing and maintaining the run-on/run-off on rail overbridges using the **asset BaFix™** system could address a few areas; including migration of ballast loss, maintaining cess walkways and protecting cable runs. Containing and supporting the ballast, particularly at the ends of the deck or structure where maintenance methods tend to raise track over time, using the **asset BaFix™** could assist these buildability issues. Maintaining the permanent way and access ways beside the track including cess walkways and run-on/run-off using the **asset BaFix™** in conjunction with **Sleeve-It** could provide new methods for design and detailing.

Improve access and safety on each side along the railway using **asset BaFix™**:

- Create a stable cess walkway which is wider and can be used for a continuous position of safety
- Create general access or wider refuge areas
- Protect cable runs
- Prevent lateral migration of ballast
- Protect trackside equipment
- Provide a ballast barrier across existing or new bridges to enable maintenance teams to view hidden defects

Using the **Sleeve-It** as an accessory with the **asset BaFix™** system:

- Provide a pre-engineered foundation solution
- Designed to resist various load configurations
- Enable key clamp barriers to be supported and installed into the cess walkway
- Enable palisade fencing to be inserted into the **Sleeve-It** and protect the rail Asset



## asset BaFix™-Geo

### Trackbed Stabilisation using asset BaFix™

#### Installation instructions for asset BaFix™-Geo

Ballast retention improves track quality and reduces the rate of deterioration over time. Loss of vertical and horizontal alignment of rails is one of the main reasons for line speed restrictions causing disruption to the general public and additional maintenance works. The **asset BaFix™-Geo** system could reduce levels of maintenance by adding a mechanical stabilised ballast layer that maintains track geometry for longer, improving whole life costs.



asset BaFix™ 50 stacked in 4 layers using a biaxial grid

#### Reducing Ballast Deformation using asset BaFix™-Geo

Stabilisation of the ballast layer or sub-ballast layer using suitable geogrids revolutionised the rail industry limiting lateral displacements.

Placing geogrid on top of the **asset BaFix™**, fastened to the first ground bar in a longitudinal direction at the bend of the front mesh at the base of the ballast layer.

This will reinforce the ballast layer adding further properties not previously realised within the rail industry.

The **asset BaFix™-Geo** is included within our **PATENT** as the latest innovative product that could revolutionise the rail industry.

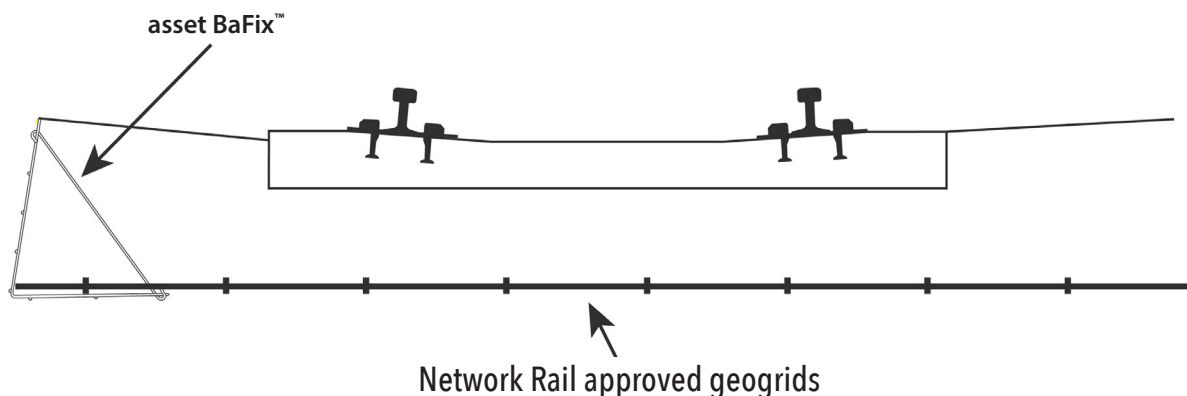

## asset BaFix™-Geo

### Trackbed Stabilisation using asset BaFix™

#### Polymer Biaxial Geogrids within the Ballast Layer

The polymer biaxial geogrid used in the example below had an optimum large aperture of 65mm square grid to reinforce the ballast layers.

Using the **asset BaFix™-Geo** will confine the ballast longitudinally using a single unit height of 50cm, 70cm, 100cm and an approved polymer biaxial geogrid will further reinforce the ballast layer preventing lateral spread and also reducing ballast settlement which drives maintenance tamping interventions.

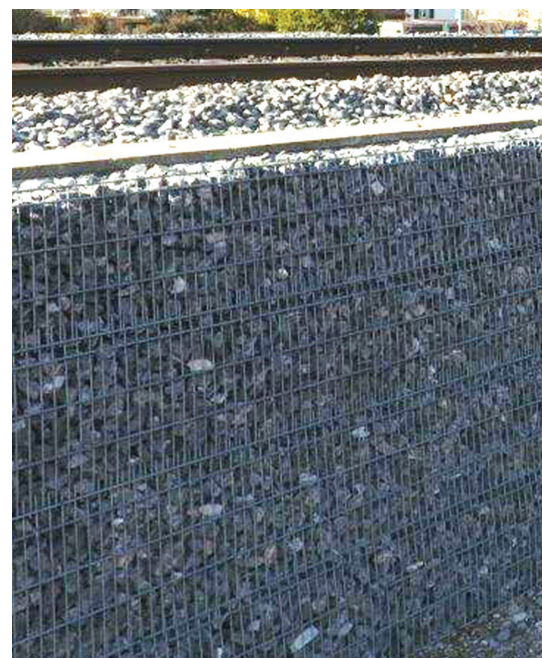

#### The asset BaFix™-Geo is also available as a Stacked System

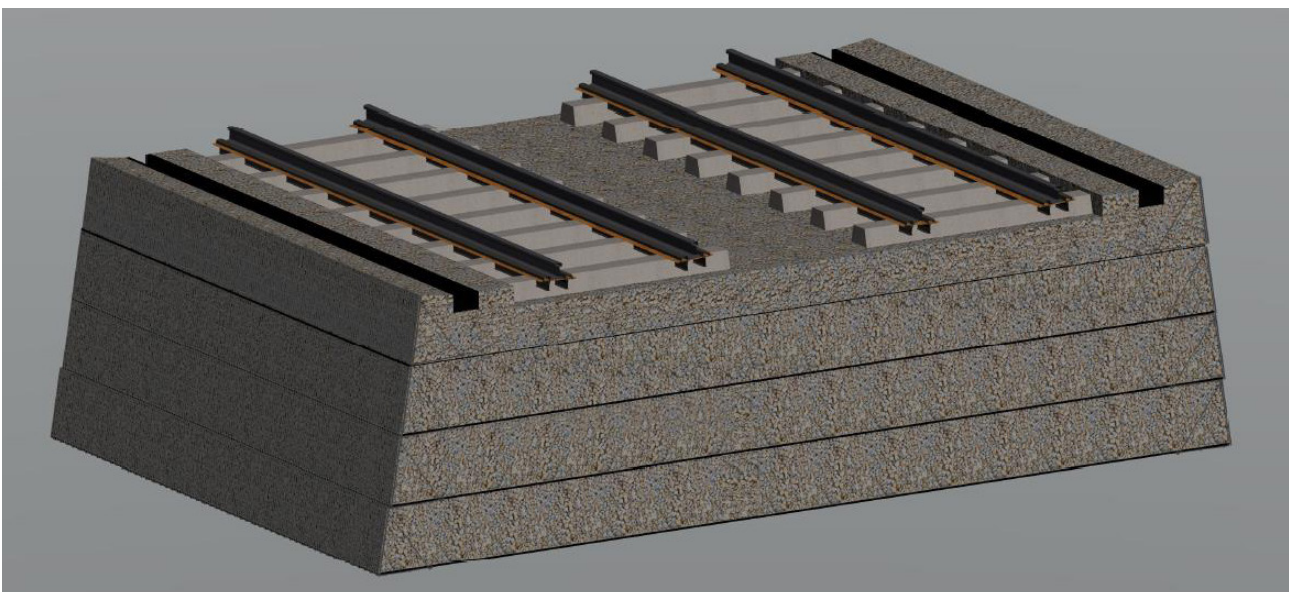

## asset BaFix™ -Geo

### Trackbed Stabilisation using asset BaFix™

#### Benefits of using asset BaFix™ -Geo

- Fully confines rail track ballast from horizontal and vertical displacements, improving ballast performance and reduces ballast settlement.
- Maintains track geometry for longer thus improving whole life costs, less disruption to operations and increased savings for the rail operator.
- Reduces ballast settlement which drives maintenance tamping interventions and increases the ballast life.
- **asset BaFix™ -Geo** unit heights of 50cm, 70cm, 100cm or stackable to cover all site conditions.
- Using rail track approved geogrids provides an effective way of reducing the rate of ballast settlement over soft subgrades.
- **asset BaFix™ -Geo** can also be used in conjunction with geocomposite drainage products.







PLEASE SCAN THIS CODE  
TO VISIT OUR WEBSITE



FOR FURTHER INFORMATION PLEASE CONTACT

**asset INTERNATIONAL STRUCTURES LTD**

Suite 5 Brecon House | William Brown Close

Llantarnam Industrial Park | Cwmbran | Torfaen | NP44 3AB

[www.assetint.co.uk](http://www.assetint.co.uk) | +44 (0)1633 499830 | [info@assetint.co.uk](mailto:info@assetint.co.uk)

